

TrueCore CF-42 Mesa Wall Panels - PUR
26 Ga. Exterior / 26 ga. Interior Facings
Allowable Load (psf) for Two or More Equal Spans

Panel Type	Design Criteria	Support Span										
		5.0	6.0	7.0	8.0	9.0	10.0	11.0	12.0	13.0	14.0	15.0
2" Thick	Connection FP1	47.4	40.5	35.4	31.5	27.8	24.9	22.5	20.6	18.9	17.5	16.0
2½" Thick	Connection FP1	47.0	40.5	35.6	31.8	28.0	25.0	22.6	20.7	19.0	17.6	16.4
3" Thick	Connection FP1	46.9	40.6	35.9	32.0	28.2	25.2	22.7	20.7	19.0	17.6	16.4
4" Thick	Connection FP1	49.2	43.8	37.6	32.5	28.6	25.5	23.0	21.0	19.2	17.8	16.5
5" Thick	Connection FP1	48.3	42.9	38.2	33.0	29.0	25.8	23.3	21.2	19.4	18.0	16.7
6" Thick	Connection FP1	47.5	42.2	38.4	33.4	29.3	26.1	23.5	21.4	19.6	18.1	16.8
8" Thick	Connection FP1	50.2	44.4	39.1	33.7	29.6	26.3	23.7	21.5	19.7	18.2	16.9

Notes:

1. The Load Span Table above is based on Allowable Stress Design (ASD). For loads calculated based on ASCE 7-10 / ASCE 7-16 (LRFD), please refer to section 2.4.1 of ASCE 7-10 / ASCE 7-16 for the applicable load combinations using Allowable Stress Design.
2. Based on CF-42 panel with 26 ga. exterior and 26 ga. interior face (min $F_y = 33$ ksi).
3. Fastener pattern FP1 is based on CF panel clips fastened to min. 14 ga. steel. Fastener options will be (2) ¼"-14 SDS Type 3, (2) ¼"-14 Self-Tapping, (2) ¼"-14 Type 5 SDS, (2) ¼"-20 Type 5 SDS, or (2) ¼"-28 Type 5 SDS. Fastener selection will be based on fastener pullout capacity from support steel members..
4. Allowable suction load is the lowest value of panel bending strength, shear strength, deflection limit and connection strength for each fastener pattern.
5. Allowable loads based on panel stress and deflection design criteria are derived from ASTM E72 structural testing and calculated with factor of safety of 2.5 for bending stress, 3.0 for shear stresses, and deflection limitation of $L/180$.
6. The panel connection strength was determined from ASTM E1592 testing and the allowable loads are calculated with factor of safety of 2.
7. The structural capacity of the purlins are not considered and must be examined independently.
8. Additional panel span / load combinations are available for other fastening pattern options; contact TrueCore engineering department for detailed analysis.
9. Panels must be checked independently for thermal stress and manufacturing and shipping considerations.

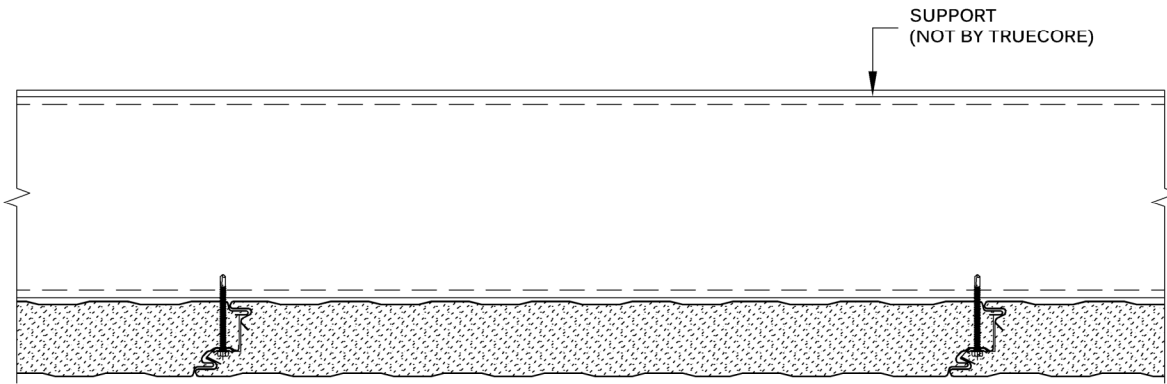

(FP1) SIDE JOINT CLIP

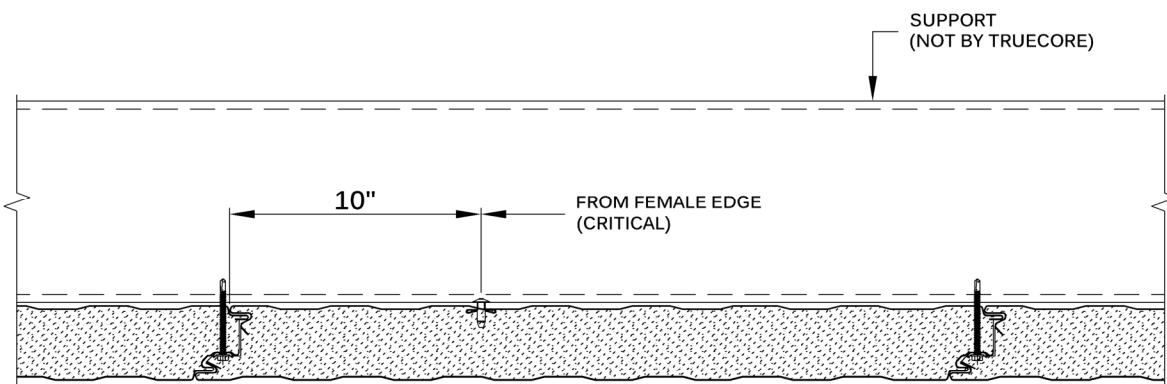

(FP2) SIDE JOINT AND (1) BULB-TITE® RIVET

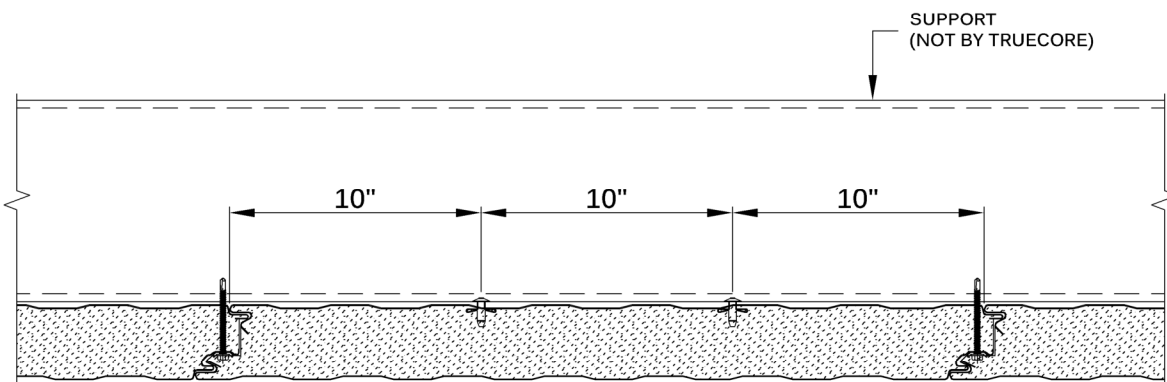

(FP3) SIDE JOINT AND (2) BULB-TITE® RIVETS

CF30 FASTENING PATTERNS

US Version - PUR

APPLICATION:
COLD STORAGE

CF30 PANEL
FASTENING PATTERNS

DRAWING NO:
TC-CS-CF30-FP-01

DATE:
MAR '22

REV:
01

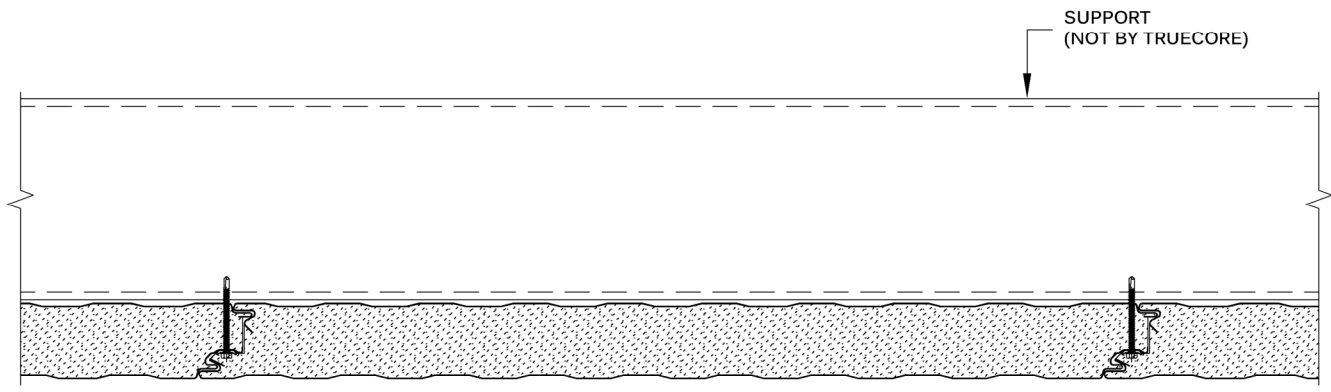

(FP1) SIDE JOINT CLIP

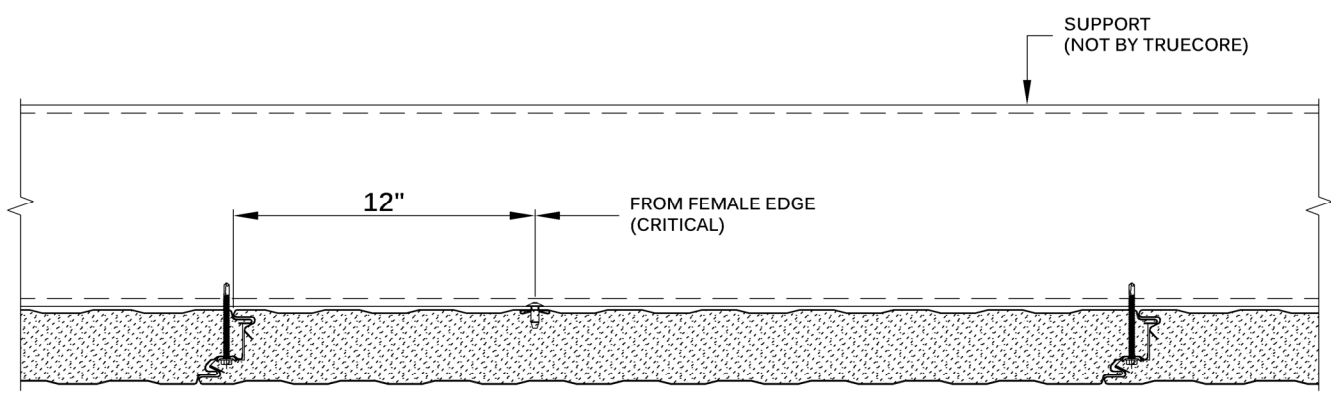

(FP2) SIDE JOINT AND (1) BULB-TITE® RIVET

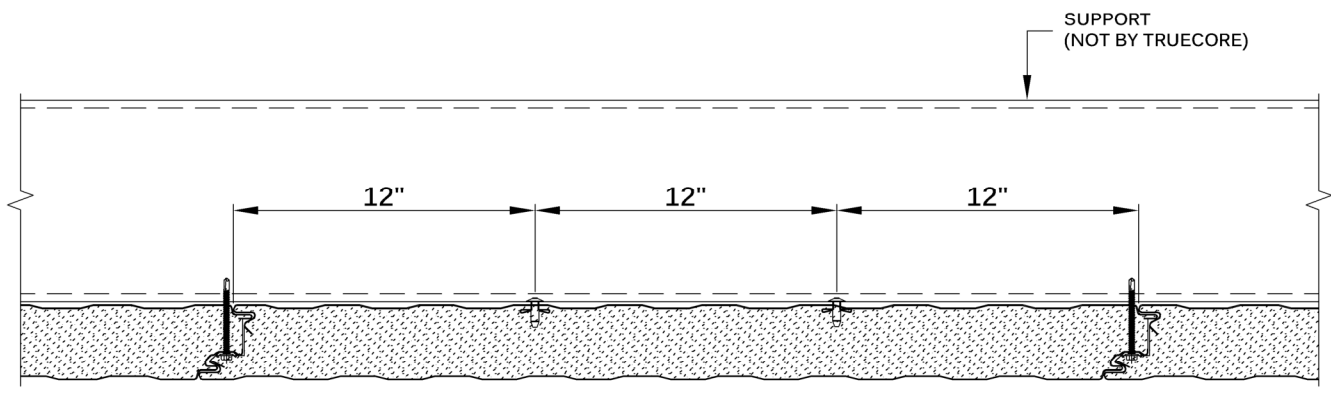

(FP3) SIDE JOINT AND (2) BULB-TITE® RIVETS

CF36 FASTENING PATTERNS

US Version - PUR

APPLICATION:
COLD STORAGE

CF36 PANEL
FASTENING PATTERNS

DRAWING NO: TC-CS-CF36-FP-01	
DATE: MAR '22	REV: 01

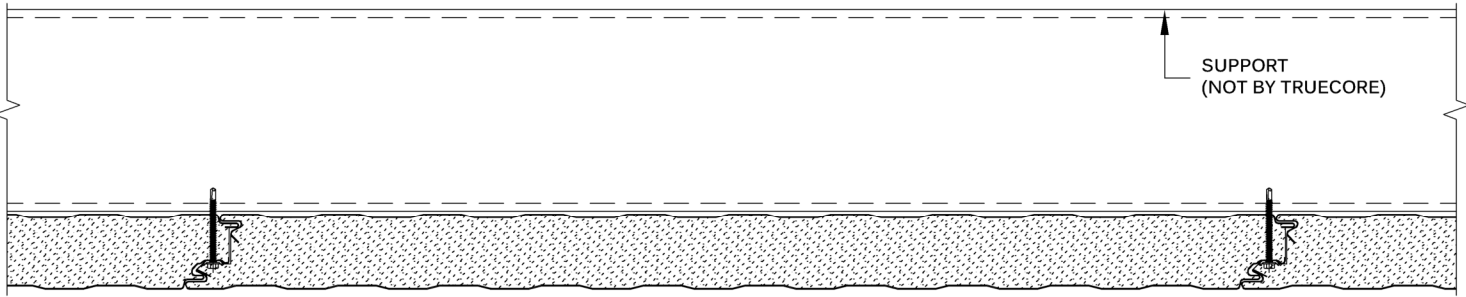

(FP1) SIDE JOINT CLIP

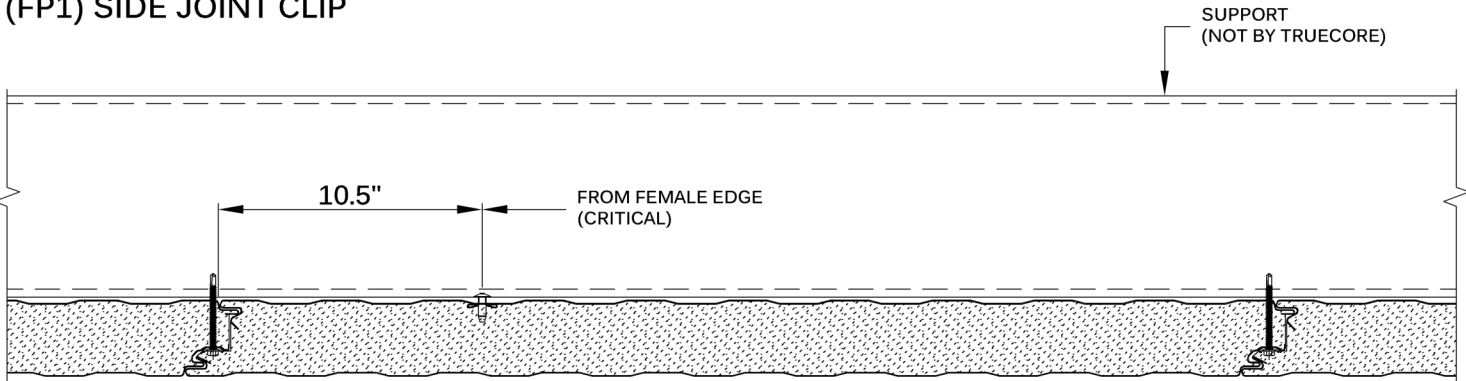

(FP2) SIDE JOINT AND (1) BULB-TITE® RIVET

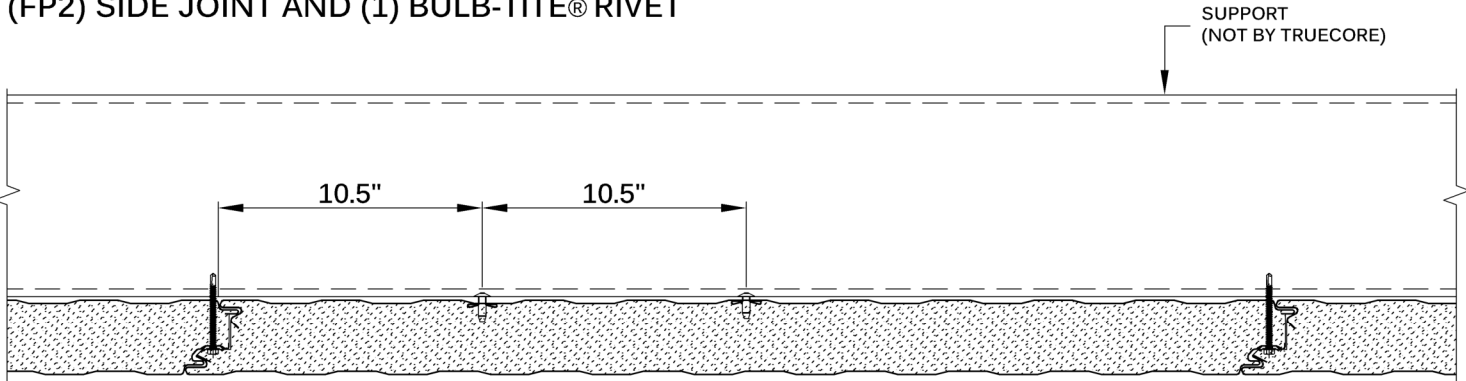

(FP3) SIDE JOINT AND (2) BULB-TITE® RIVETS

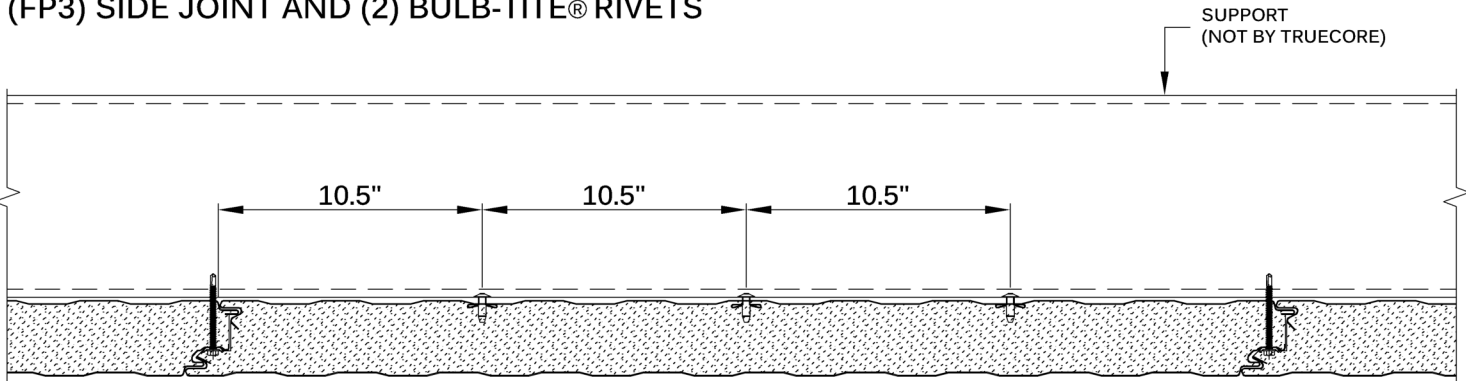

(FP4) SIDE JOINT AND (3) BULB-TITE® RIVETS

CF42 FASTENING PATTERNS

US Version - PUR

APPLICATION:
COLD STORAGE

CF42 PANEL
FASTENING PATTERNS
1 OF 2

DRAWING NO:
TC-CS-CF42-FP-01

DATE:
MAR '22

REV:
01

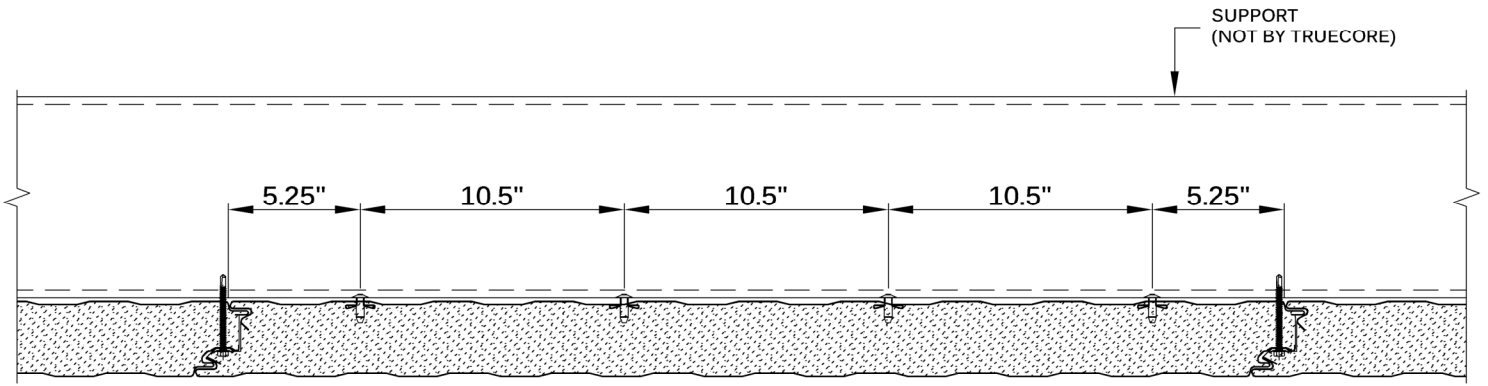

(FP5) SIDE JOINT AND (4) BULB-TITE® RIVETS

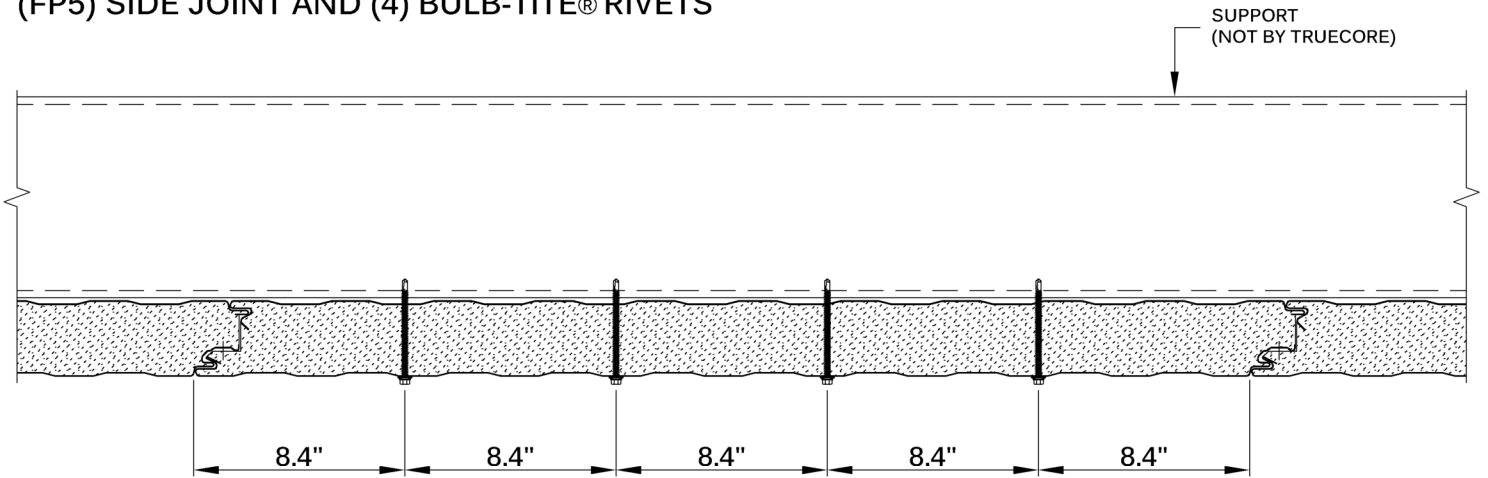

(FP9) (4) SELF-DRILLING OR SELF-TAPPING FASTENERS
W/ NEOPRENE BONDED WASHER

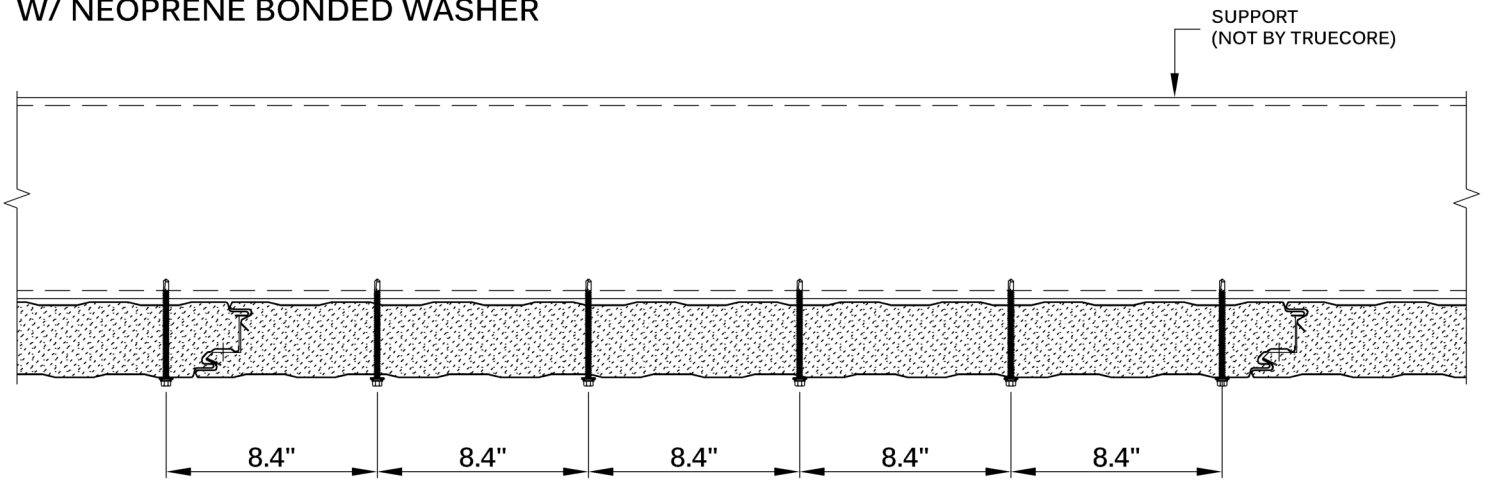

(FP10) (5) SELF-DRILLING OR SELF-TAPPING FASTENERS
W/ NEOPRENE BONDED WASHER

CF42 FASTENING PATTERNS

US Version - PUR

APPLICATION:
COLD STORAGE

CF42 PANEL
FASTENING PATTERNS
2 OF 2

DRAWING NO:
TC-CS-CF42-FP-02

DATE:
MAR '22

REV:
01